

OPERATION MANUAL



IL-ND



IL-ND 6 Ton Streamline Compression Tool

Read and understand all of the instructions and safety information in this manual before operating or servicing this tool.



195 Internationale Blvd
Glendale Heights, IL 60139
Phone 800-860-6170
Fax 800-345-3767
www.spartacogroup.com

THANK YOU...

for purchasing an Huskie Tools product. Our mission is to supply the finest steel cable connecting and cutting tools and cable-related products to the transmission and distribution markets. Huskie Tools represent state-of-the-art tools that are dependable and safe. All products will carry an unconditional guarantee to be free from defects and to perform as advertised.

Please take the time to read this manual carefully to learn how to correctly operate and maintain your tool.

Table of Contents

Registration/ Contents.....	2
Warranty.....	3
Safety.....	4
Kit Includes.....	5
Specifications.....	6
Operating Instructions.....	7
Operating Instructions (Part 2).....	8
Operating Precautions.....	9
Breakdown.....	10
Parts List.....	11
TroubleShooting Guide.....	12

Warranty

Huskie Tools products carry a warranty that makes us a leader in the tool industry. No other manufacturer dares to back its tools as we do.

All Huskie REC-SERIES battery operated products carry a 5 year warranty. The ECO-SERIES battery operated products carry a 1 year warranty. The BP-80 & BP-84 batteries carry a 5 year warranty from the date stamped on the battery. The BP-82 battery carries a 1 year warranty.

PRODUCT WARRANTY

REC-Series battery operated products	5 Years
ECO-Series battery operated products	1 Years
Batteries (BP-80, BP-84)	5 years/ (BP-82) 1 year
Chargers (CH-90, CH-94)	5 Years

The warranty does not cover any damages incurred from a Huskie tool including damages to property, bodily injuries and lost wages resulting from such injuries. This warranty solely covers the repair or replacement of tools supplied by Huskie. These remedies are exclusive, and the total liability of Huskie Tools, LLC whether based on contract, warranty, negligence, indemnification, strict liability or otherwise, shall not exceed the purchase price of the tool. In no event shall Huskie Tools, LLC be liable for consequential, incidental or special damages.

HUSKIE TOOLS, LLC MAKES NO OTHER WARRANTIES OF ANY KIND, EXPRESSED OR IMPLIED, AND ALL IMPLIED WARRANTIES INCLUDING ANY WARRANTY OF MERCHANTABILITY AND FITNESS FOR A PARTICULAR PURPOSE ARE DISCLAIMED.

Huskie reserves the right to determine all warranty claims. Huskie will not warranty tools containing parts or batteries not originally supplied by Huskie. Failure due to misuse, improper maintenance, misapplication, not following instructions or warnings, abuse or repairs attempted by anyone other than Huskie Tools, LLC, or an authorized service center renders this warranty null and void.

Repair and Warranty Claims

All claims must be sent to Huskie for inspection and authorization. A Return Goods Authorization (RGA) is required before shipping tools to Huskie. Secure the authorization by telephoning or writing to Huskie's main office with details of the claim. Non-warranty repairs are handled using the same procedure. Repairs exceeding 50 percent of the cost of a new tool will be advised before repairs are made.

Payment Terms

Upon credit approval Huskie's standard payment terms are net-30 days. Visa, Mastercard, Discover and American Express are also accepted.

Freight

All Huskie tools are FOB, Glendale Heights, Illinois. Goods will be shipped pre-paid and added, unless otherwise specified. Freight shipments over \$17,000 are pre-paid.

Quotations

Special quantity quotations should be phoned in to discuss the scope of your tool requests.

Complete Support Services

Our customers have direct access to us for training, service, and problem solving. As specialists in tools, we maintain a trained repair staff and a large stock of parts. This contrasts with many tool suppliers who carry tools as a sideline without offering support services. Here are some reasons why our customers love to do business with us:

- Quick delivery
- We maintain inventory at our headquarters.
- Training and troubleshooting services.
- Fast repair service.
- Design and engineering service for special tool needs.



Safety Alert Symbol:

This safety alert symbol indicates a potential personal injury hazard; it is not used for messages related to property damage only.

CAUTION



**Wear eye
protection**

Wear eye protection:

when operating this tool.
Failure to wear eye protection could result in serious eye injury from flying debris or hydraulic oil.

DANGER



**Electrical
hazard**

Electric Shock hazard:

Use proper personal protective equipment when using this unit on or near energized electrical lines.

Pinch Point Hazard:

Compression Dies at high force can cause severe personal injury. Keep all body parts away from moving parts of the tool while operating.





- 1 Battery Powered Tool
- 1 Carrying Case
- 1 CH-94 Charger
- 2 BP-84 Lithium Ion Batteries
- 1 Carrying Strap

Battery and Charger

- BP-84 Huskie Tools Lithium Ion Batteries
- CH-94 Huskie Tools Charger
- This charger can charge the BP-84, BP-82 and BP-80 only. Huskie Tools batteries, including the BP-70, BP-70E1 and the BP-70MH must be charged with the CH-90, CH-80, or previous charger models.

Add Ons:
HT58-Series "W" Dies



OPTIONAL ACCESSORIES

3 Jaw Types to Choose From



ILBG-JAW



ILO-JAW



ILND-JAW

The newly developed **IL-ND** streamline tool was designed as an upgrade to the ECO-EZ tool giving the user a more robust product with a true 3 year life cycle.

Enhancements to the hydraulic system includes a more robust heavy duty motor similar to the "SL" tool. We also re-designed compression head to utilizes less hydraulic force while delivering a 6 ton output compression force. We have also added a rubber over-mold to the housing that will allow the operator better tool control with the non-slip grip, as well as an updated aesthetic look, separating it from the competition.

IL-ND

Specifications

Output	6 Ton
Weight	7.3 lbs. with Battery
Size	3.37" L x 21" H x 3.1"W

Crimping Estimates

	BP-84
4/0 - 4/0 H-Tap	100

Connector Range

Lugs and Splices	#8-500 MCM Cu #8-350 MCM Al
H-Taps	Up to 4/0-4/0

Features

- Lightweight ergonomic design
- One handed operation
- Tested up to 75kV
- Compatible with all Huskie 14.4V Batteries
- 3 Year Warranty

CHARGING THE BATTERY

1. Insert the plug end into a 120V power source. The LED (Power) indicator will be steady green indicating the charger is now in “stand-by” mode and ready to charge the battery. Do not plug the charger into a generator as this will likely cause the fuse in the charger to short, and will not operate.
2. To charge a drained battery, insert the battery into the charger. The LED indicator shows a steady amber while charging. A depleted battery will be completely charged in approximately 50-70 minutes. The LED indicator will show a steady green when the battery is fully charged.
3. If the LED indicator goes out or is flashing quick amber, this could be a possible short in the battery circuit, or a problem with the charger itself. It is best to consult the factory at 1-800-860-6170 for service if such a condition occurs.
4. For technical questions or difficulty in operation, please call our customer service department at 1-800-860-6170.



ATTACHING THE BATTERY CARTRIDGE

1. While pressing the latch, pull out the battery cartridge. To replace the battery cartridge, push the new cartridge firmly into place.
2. After inserting a battery cartridge, check that it is securely in place by pulling gently. Do not press the latch when pulling the cartridge.

TRIGGER AND RELEASE BUTTON

1. The ram advances when the trigger is pressed and stops when the trigger is released.
2. To retract the ram, push the release button. The ram continues to retract while the release button is pressed.

COMPRESSION

1. Select an appropriate size of die for the connector. Insert half of the dies into the jaw by pressing the push pins. When the push pins are released, they will return to their original position and hold the die in place. Attach the other half of the die in the same manner.
2. Place the connector between the dies press the trigger and advance the ram so that the connector is held between the dies and insert conductor into the terminal.
3. Press the trigger until the compression is completed. A clicking sound will be heard while crimping and will stop once the crimp is completed.
4. Press the release button to retract the ram. The ram continues to retract while the release button is pressed. The ram stops when it reaches the lower end.

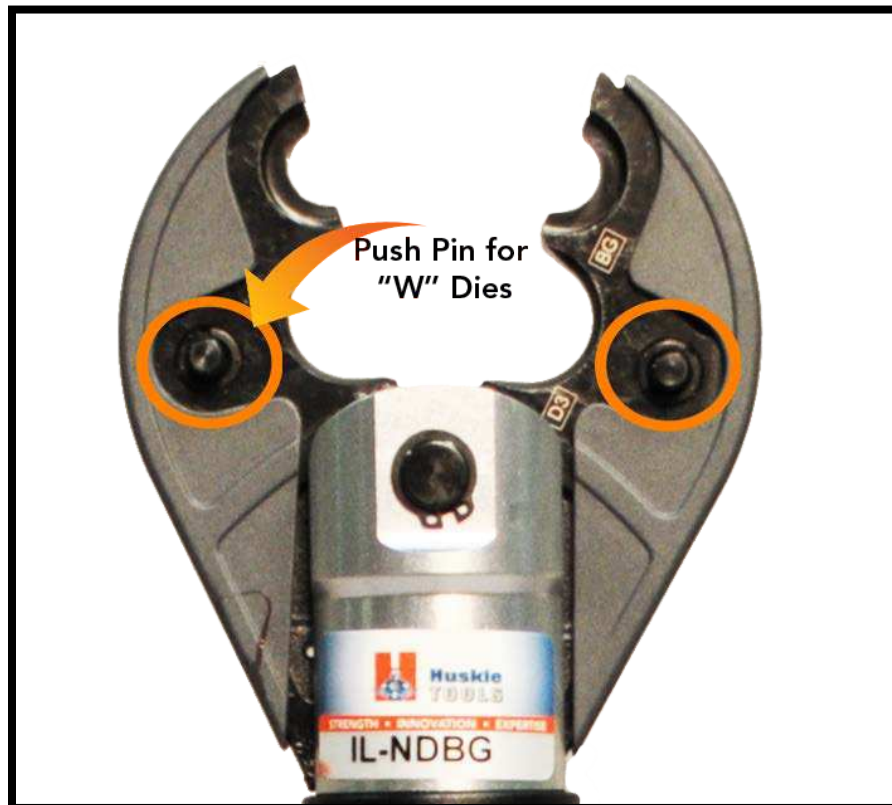

MAINTENANCE AND INSPECTION

1. Daily maintenance is required to ensure that the tool is kept in good working condition.
2. Do not store the tool in a humid environment.
3. Wipe away any excess oil with a soapy cloth.
4. Provided that maintenance of the tool is carried out regularly, the tool should provide many years of service.
5. Should you experience any difficulty with the operation and maintenance of this tool, contact Huskie's technical support department at 1-800-860-6170.

PRECAUTION FOR THE TOOL

1. Select appropriate dies for the connector to be compressed. Incorrect combinations result in inferior connections of the conductors. Consult your connector manufacturer for the recommended die/connector combinations.
2. Always point the tool AWAY from other people.
3. If the tool is stored for an extended period at a temperature of less than 25° F (-5°C), the tool should be allowed to return to room temperature to ensure smooth operation Use the tool only after it has been at room temperature for 1 hour.
4. Do not drop the tool. Dropping the tool may damage the hydraulic circuit and result in the tool not functioning correctly.
5. Keep the head and ram clean and free of debris. Solvents can be used to clean the head, but should not be used on the plastic body. Use soap and water to clean the body.
6. Do not use tool for continuous use. If any sign of over heating, allow the tool to cool for 15 mins.
7. Do not allow tool to be submerged in water. The tool may be used to in damp or wet environments. However it is recommended for tool to be air-dried before use.

PRECAUTION FOR THE BATTERY CARTRIDGE

1. Do not short circuit the contacts or expose the cartridge to water, oil or solvents.
2. Do not disassemble or attempt to repair the battery cartridge or dispose of in a fire.
3. Do not drop or otherwise abuse the battery cartridge.
4. Do not leave the cartridge in locations where it will be exposed to a temperature greater than 140°F (60°C) for an extended period.
5. The battery has a limited life. When the crimping capacity becomes about 1/2 that of the original capacity, the battery should be replaced.
6. If the battery cartridge is stored without being charged, natural drainage will cause the power to be reduced. The battery should be charged every 3 months if not in use.

PRECAUTION FOR THE CHARGER

1. The LED indicator lights up amber and remains lit when the unit starts charging a battery cartridge. The indicator turns green when charging is completed.
2. The BP-84 can be charged with any of the Huskie Lithium-Ion chargers including the CH-80, CH-90 & CH-94.
3. Allow battery cartridges to cool before charging. Allow at least 15 minutes between charges when charging several cartridges in succession.
4. Charge batteries at an ambient temperature of 50°-95°F (10°-35° C). Charging time is approximately 50-70 minutes for the BP-84.
5. Never short circuit the output terminals.
6. Do not expose the charger to water, oil or solvents.
7. Do not disassemble, attempt to modify, drop or otherwise abuse charger.

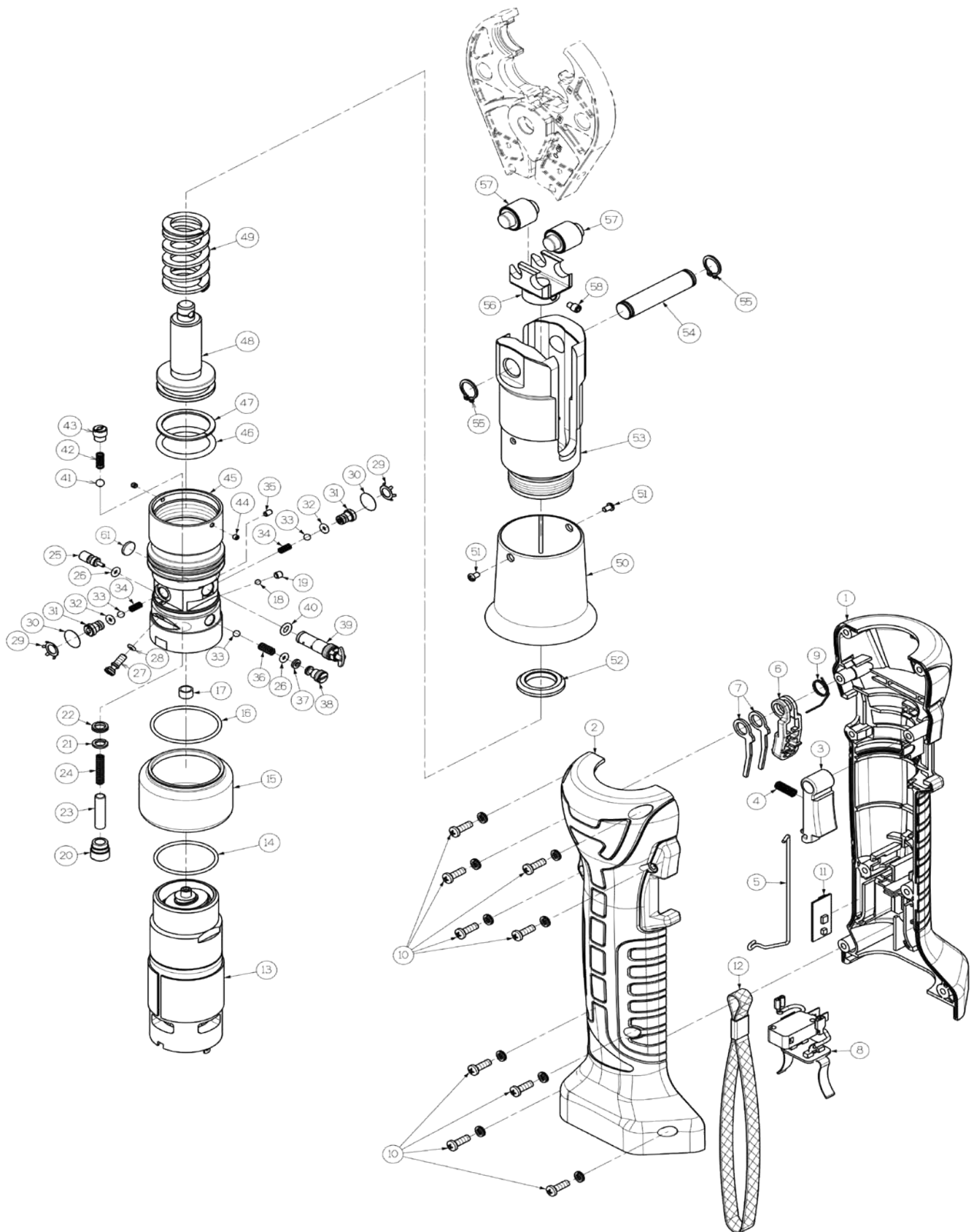

No.	Description	Code Number	Qty
1	Housing set	ILHS-BLUE	1
2			
3	Switch Knob	IL-03	1
4	Spring	4OU-10	1
5	Switch Rod	IL-05	1
6	Release Lever	EZ-07	1
7	Lever Support	EZ-06	2
8	Switch Unit	EZ-05	1
9	Release Spring	EZ-08	1
10	M4 x 12Screw	P500-28	9
11	ICB	IL-11	1
12	Strap	558-07	1
13	Power Unit	IL-13	1
14	S-32 O-Ring	EZ-10	1
15	Oil Reservoir	EZ-11	1
16	S-36 O-Ring	EZ-12	1
17	Bush	R14A-19	1
18	1/8" Ball	40-20	1
19	M4 x4 Screw	85-47	1
20	Cylinder Insert	EZ-13	2
21	Back-Up Ring	UC-28	2
22	S-6 Pent Seal	EZ-14	2
23	Pump Piston	EZ-15	2
24	Spring	EZ-16	2
25	Release Valve Stem	EZ-17	1
26	P-3 O-Ring	16-36	2
27	Reservoir Plug	EZ-18	1
28	S-3 O-Ring	7R-17	1
29	SI-Ring	R14A-23	2
30	Filter	EZ-19	2

No.	Description	Code Number	Qty
31	Suction Valve	EZ-20	2
32	P-3 O-Ring	EZ-21	2
33	5/32" Steel Ball	22-21	3
34	Valve Spring	EZ-22	2
35	M3X5 Screw	UC-37A	1
36	Release Spring	EZ-23	1
37	P-3 Back-Up Ring	9H-38	1
38	Release Plug	EZ-24	1
39	Valve Cartridge	EZ-25	1
40	P-5 O-Ring	5N-35	1
41	3/16" Ball	16-49	2
42	Valve Spring	EZ-26	2
43	Valve Screw	EZ-27	2
44	M3X4 Screw	ND-01	2
45	Body	EZ-28	1
46	P-28 O-Ring	EZ-29	1
47	P-28 Back-Up Ring	55D-03	1
48	Ram	IL-48	1
49	Ram Spring	EZ-31	1
50	Cover	IL-50	1
51	M3x5 Screw	13S-23	2
52	Guide Ring	IL-52	1
53	Body Head	IL-53	1
54	Pin	IL-54	1
55	Snap Ring	IL-55	2
56	Roller Head	IL-56	1
57	Roller	IL-57	2
58	Screw M5XL8	IL-58	1
61	Magnet	336-64	1

PROBLEM	CAUSE	SOLUTION
MOTOR RUNS, BUT THE TOOL JAWS WILL NOT ADVANCE	Insufficient Hydraulic Oil	Consult Factory for Repair Service
	Air Block in Hydraulic System	Invert tool to allow air to rise towards the top of the oil bladder
	Defective Hydraulic Circuit	Consult Factory for Repair Service
MOTOR RUNS, TOOL JAWS ADVANCE, BUT WILL NOT BUILD PRESSURE	Insufficient Hydraulic Oil	Consult Factory for Repair Service
	Defective Suction Valve or Bypass Cartridge	Consult Factory for Repair Service
MOTOR WILL NOT RUN AT ALL	Defective Battery	Charge or Replace Battery
	Bad Contact or Loose Battery Connections	Check all Connections and Wires
	Misaligned Switch	Check to Make Sure that Switch is Properly Aligned with Trigger
		Consult Factory for Repair Service
TOOL JAWS WILL NOT RELEASE	Tool Did Not Complete a Full Cycle and Bypass	Press Trigger and allow Tool to Bypass, Then Release Tool Jaws
	Connector is Jammed in Tool Jaws	Press and Hold Release Trigger While Prying Tool Jaws Apart
	Release Trigger is Bent or Misaligned	Consult Factory for Repair Service



NOTES



NOTES



NOTES



195 Internationale Blvd
Glendale Heights, IL 60139
Phone 800-860-6170
Fax 800-345-3767
www.spartacogroup.com